



Excellence in Monitoring

Ronan Model X90 Series Point Level Monitor

For more than 27 years Ronan has provided the process control industry with unsurpassed products in the harshest environments. With a philosophy of designing new products to be backward compatible, our customers have the confidence of an installed base of thousands of systems. A worldwide network of dealers, 24-hr factory certified Field Service Engineers and an experienced staff of Applications Engineers are ready to assist with your measurement needs.

Product Information



Integral Mount Electronics

The X90 Point Level Monitor detects the presence or absence of material at a given point in a tank, hopper, chute or process pipe. All components are mounted externally to the process vessel making the system ideal for monitoring the most dangerous materials such as caustic, toxic, corrosive, explosive, and carcinogenic irrespective of their temperature. The modular design is ideal to upgrade older systems while keeping the existing sources.

Applications

- Solids and Liquids Measurement
- Measurement Not Affected by:
 - Dust or Moisture
 - High Temperatures
 - Corrosive, Abrasive or Toxic Materials

Features and Benefits

- Lowest Activity Sources on the Market
- Remote or Integral Electronics
- Remote Mount in 1 to 7 Unit Chassis.
- Programmable Through Hand-Held Communicator
- Low Maintenance / No Component Wear





Excellence in Monitoring



Measurement Principle

Each point level system consists of a gamma source, detector and either integral or remote mount electronics. The detector receives energy at a level dependant upon the presence or absence of the process material inside the pipe or vessel. Applications requiring both high, and low-level alarms, or the monitoring of several points may, in many cases, utilize the same source.

The electronics unit converts the pulse output of the detector and provides a DPDT (double-pole, double-throw) contact output, which represents the change in status between the presence and absence of material. This electronics unit may be mounted integrally to the detector or at a remote location.



Excellence in Monitoring

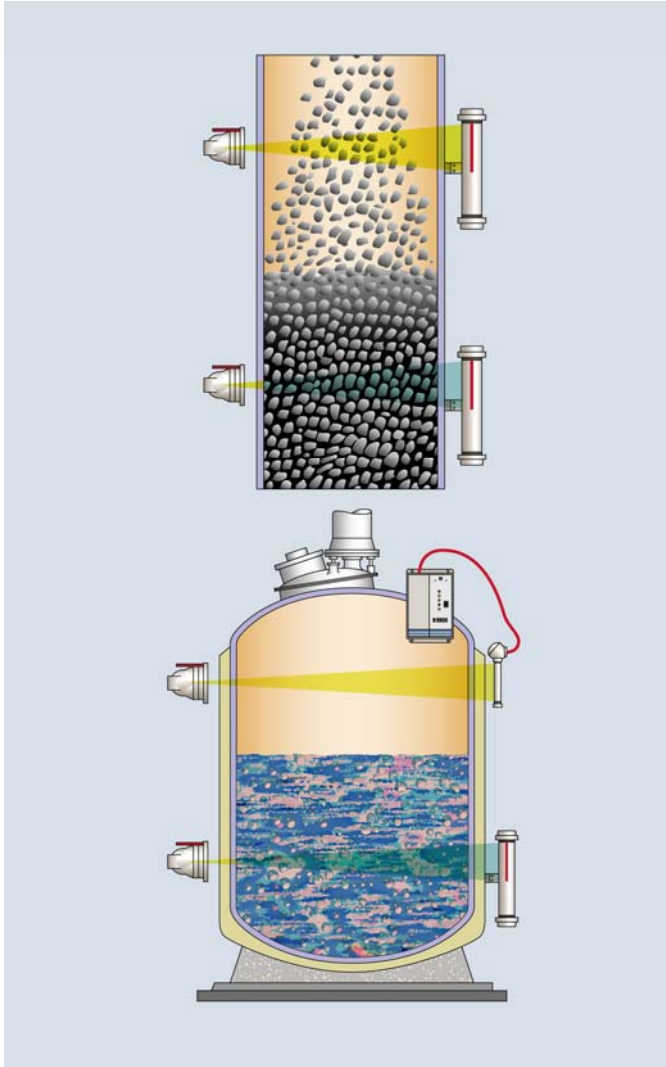

Source Holders

Ronan pioneered the development of ultra-low level sources to greatly improve safety, and eliminate the requirement for surveys, wipe tests, inspections and much of the documentation. They are so safe the NRC permits their removal and installation without a licensed person being present, translating into significant cost savings for the user.



Excellence in Monitoring

The RLL-1 ultra low source utilizes very small quantities of radioactive materials. RLL is a Ronan Engineering term that stands for "Radiation Low Level." RLL technology utilizes up to a total of 0.9 mCi (0.033 GBq) of cesium source. In comparison, some conventional weight gamma gauges use source sizes with a hundred times more activity to make the same measurement. Because of these very low-levels of activity, and their simplicity of design, Ronan systems are the safest gamma gauges on the market. The NRC recognized this in 1999 when Ronan Engineering attained certification for the first RLL source design.



RLL-1 Low level Source Holders



LS Source Holders



SA-1 Source Holder

The LS series of source holders are approved for General License installations on level applications when used with an interlock device. The source is available in both single (LS-S) and dual (LS-D) port configurations for installations where vessels are close to each other and one source can be used on both. i.e. Flyash Hoppers

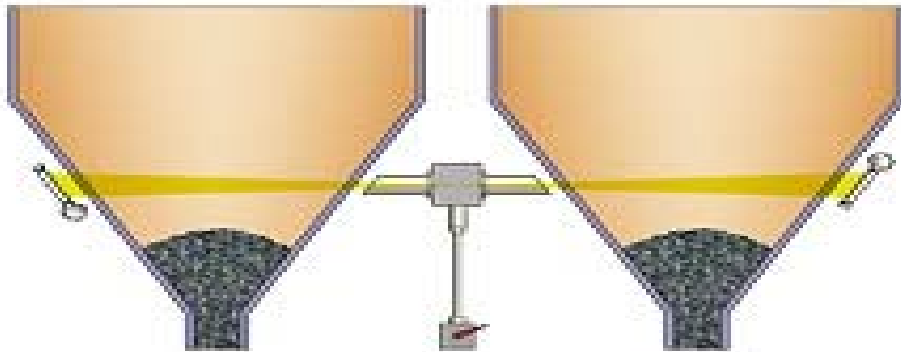



Excellence in Monitoring

Specifications

X90 Programmable Integral Electronics



Performance

System Accuracy	+/- 0.25" (6.35 mm)
Switching Time	Nominally 1 second
Outputs:	
Relay	SPDT 5A at 30 VDC Res.; 2A at 30 VDC Ind.; 5A at 250VAC Res.; 3A at 150 VAC Ind.
Open Collector	100 mA at 30VDC
Diagnostics	On-Board Modular Self-Test Watchdog Timer and Status LEDs
Calibration	Available Through Hand Held Communicator (RS485) or Local Push Button

Environmental

Operating temperature	-40 to +60° C (-40 to 140°)
-----------------------	-----------------------------

Electrical

Power supply	110/220 VAC @1A or 24 VDC @ 0.3 A.
Power Consumption	7 Watts Per Alarm Point

Mechanical

Construction	Housing	- 4 inch Diameter Schedule 40 Carbon Steel Explosion Proof - Stainless Steel Optional
	Paint	Protective Coating; Epoxy Based
	Weight	Approx. 37.4 lbs (17 kg)

Approvals

Class I, Div 1 Groups A,B,C,D; Class II, Div I, Groups E,F,G
Nema 4, Nema 4X

Warranty

Three Year Limited Warranty



Excellence in Monitoring

X90 Programmable Remote Electronics



Performance

System Accuracy	+/- 0.25" (6.35 mm)
Switching Time	Nominally 1 second
Outputs:	
Relay	SPDT 5A at 30 VDC Res.; 2A at 30 VDC Ind.; 5A at 250VAC Res.; 3A at 150 VAC Ind.
Open Collector	100 mA at 30VDC
Diagnostics	On-Board Modular Self-Test Watchdog Timer and Status LEDs
Calibration	Available Through Hand Held Communicator (RS485) or Local Push Button

Environmental

Operating temperature	-40 to +60° C (-40 to 140°)
-----------------------	-----------------------------

Electrical

Power supply	110/220 VAC @1A or 24 VDC @ 0.3 A.
Power Consumption	7 Watts Per Alarm Point

Mechanical

Chassis		
	Single	Surface Mount Chassis. General Purpose Enclosure: One Module
	Weight	Approx. 10 lbs (5 kg)
	Single	Surface or Rack Mount Chassis. General Purpose.. Holds up to Seven Modules

Warranty

Three Year Limited Warranty



Excellence in Monitoring

Ronan Scintillation Detector

Ronan pioneered the use of solid crystal scintillation detectors more than 20 years ago, and now has an installed base in the thousands across a wide variety of applications worldwide. Ronan employs two types of crystals: Scintillating Plastic Crystals for standard low-level applications, and Sodium Iodide scintillating crystals for ultra low-level fields. For point level applications, scintillation detectors are used for low level fields.



Features

- High Detector Efficiency
- Spring Tension of PM Tube. Maintains Integrity of the Signal Path Under Vibration and When Detector is Mounted Inverted
- Lowest Gamma Fields in Industry
- Ronan Quality Manufacturing-Backed by a Three Year Limited Warranty



Excellence in Monitoring

Scintillation Detector Specifications

Performance	
System Accuracy	+/- 1 % span
Environmental	
Operating temperature	-10 to +60 C (Low Temperature and High Temperature Options Available)
Electrical	
Power supply	24 VDC @ .035 A
Mechanical	
Construction	Electronics - Stainless Steel Housing - Schedule 40 Carbon Steel, Epoxy Painted - 304 Stainless Steel Optional - PVC Optional
Scintillation Crystal	Plastic or Sodium Iodide
Weight	15 lb/ foot
Approvals	
	Complies with Cenelec/Atex CSA Class 1, Div 1 Groups A,B,C,D Nema 4, Nema 4X
Warranty	
	Three Year Limited Warranty



Excellence in Monitoring

Ronan High Sensitive Geiger- Müller Tube Detector

Ronan Geiger Müller Tube Detectors consists of a gas-filled tube containing electrodes, between which there is an electrical voltage, but no current, flowing. When ionizing radiation passes through the tube, a short, intense pulse of current passes from the negative electrode to the positive electrode and is measured or counted. The number of pulses per second measures the intensity of the radiation field. These pulses are directly proportional to the process mass being monitored and the electronics are then calibrated for the desired alarm status. For point level applications, Geiger Müller Tube detectors are used for high fields.





Excellence in Monitoring

High Sensitive Geiger- Müller Tube Detector Specifications

Performance	
System Accuracy	+/- 1 % span
Environmental	
Operating temperature	-10 to +60 C (Low Temperature and High Temperature Options Available)
Electrical	
Power supply	Powered from Electronics
Mechanical	
Construction	Stainless Steel
Weight	Approx. 3 lbs
Warranty	
	One Year Limited Warranty



Excellence in Monitoring

Programmable Integral Switch

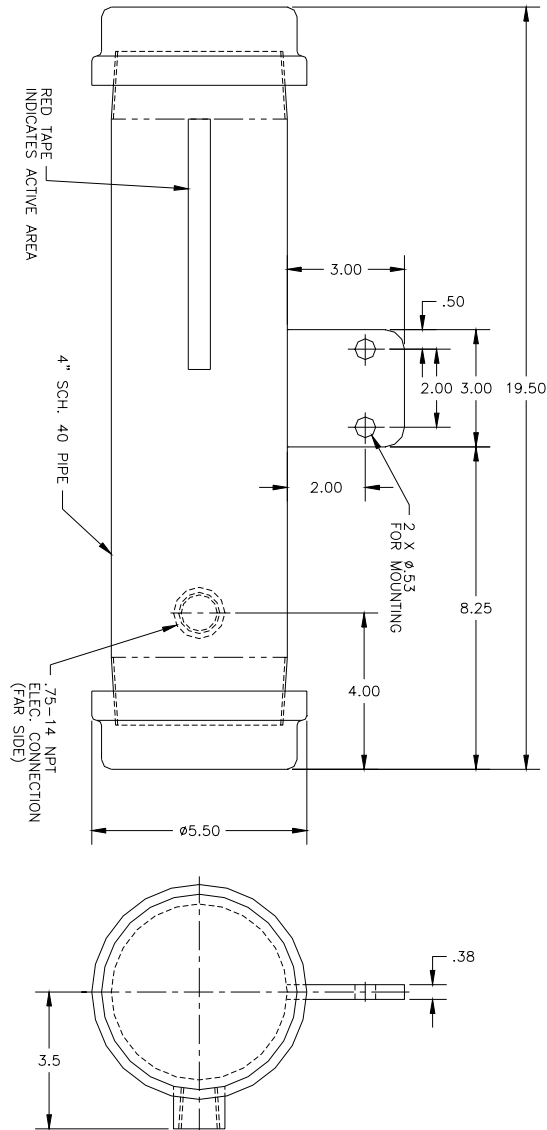



Excellence in Monitoring

Programmable Multi-Point Surface Mount

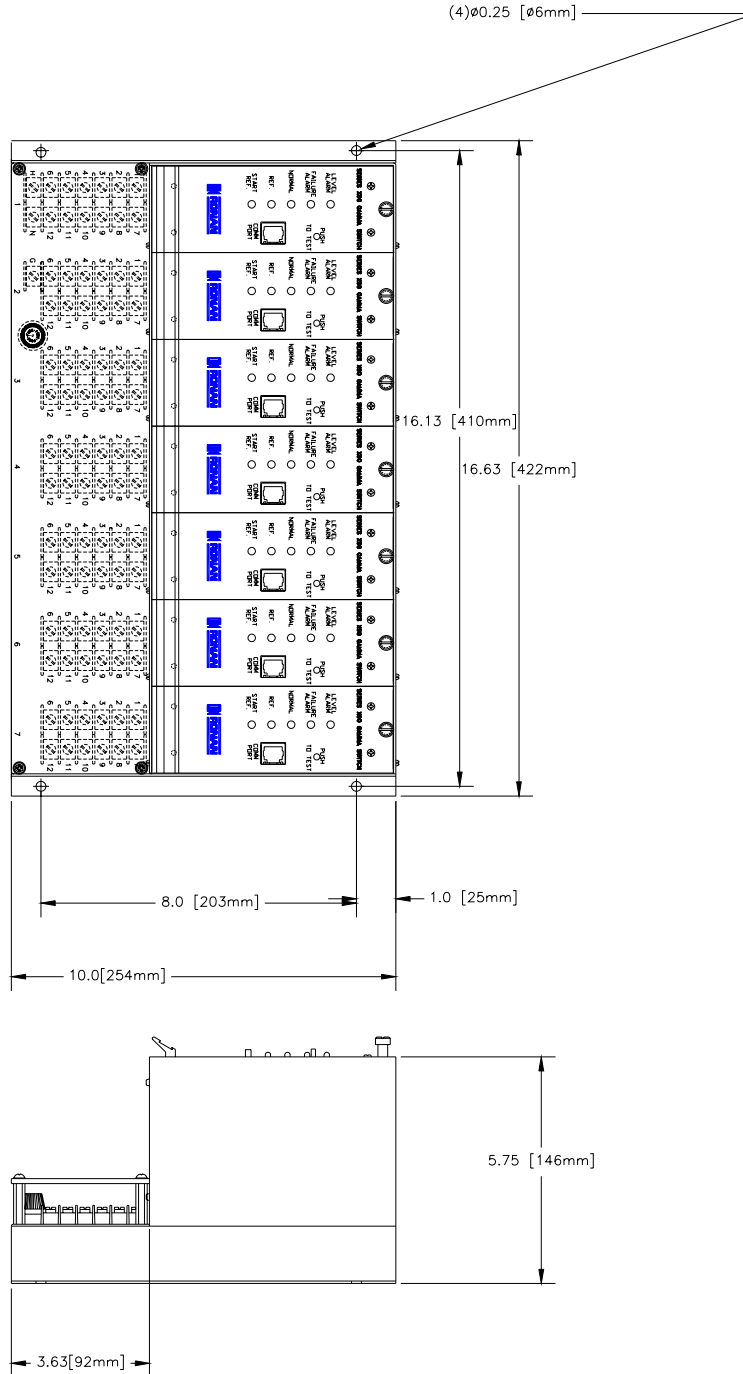

Ronan Measurements Division • 8050 Production Drive Florence, KY 41042
 (859) 342-8500 • FAX (859) 342-6426
 www.ronanmeasure.com • E-Mail: ronan@ronanmeasure.com



Excellence in Monitoring

Programmable Single Point Surface Mount

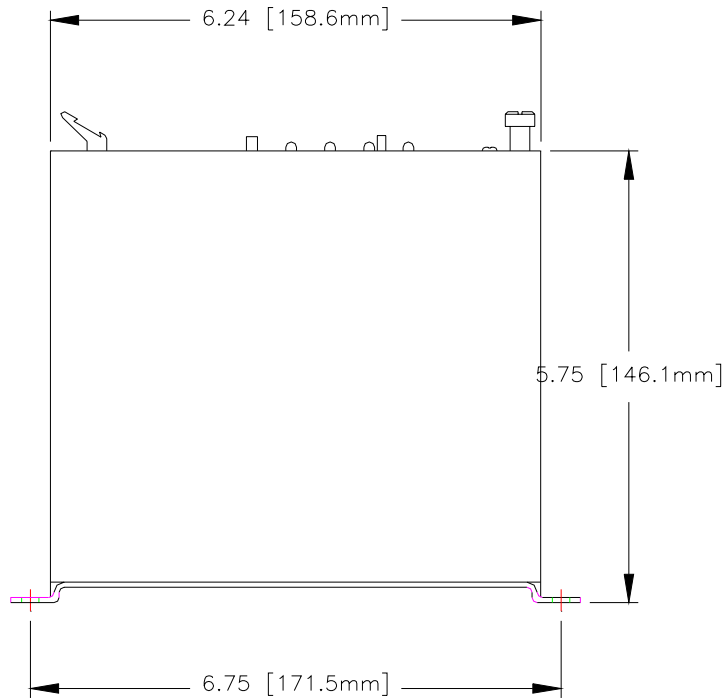
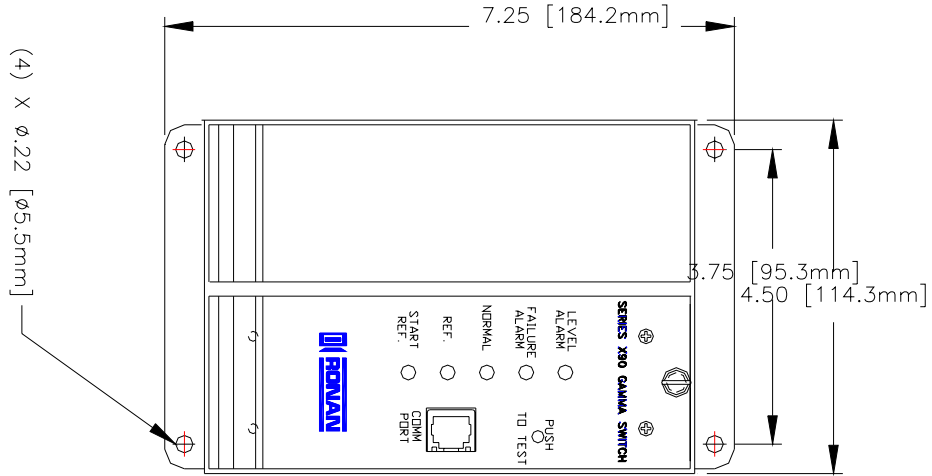



Excellence in Monitoring

Programmable Multi-Point Rack Mount Switch

